

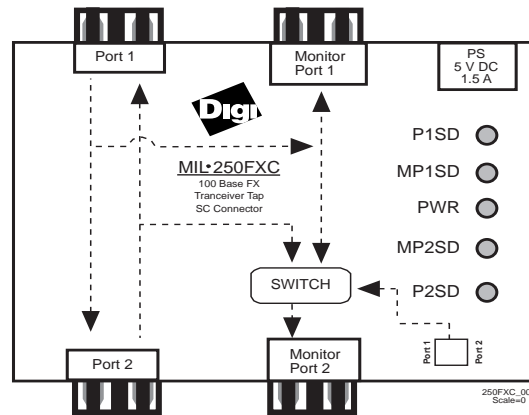

MIL•250FXC 100 Base FX Transceiver Tap



Installation Guide

This guide includes the following information:

[“Introduction” on page 2](#)

[“Installation” on page 2](#)

[“Indicators” on page 3](#)

[“Switch Setting” on page 4](#)

[“Specifications” on page 4](#)

[“Legal” on page 6](#)



Introduction

The MIL-250FXC is a 100BaseFX multi-mode fiber transceiver tap that allows a user to monitor network traffic flowing on either direction of a link connection. The device contains four ports:

- Port 1
- Port 2
- Monitor port 1
- Monitor port 2

When the unit is operating, port 1 and port 2 are connected to two Fast Ethernet devices, which may be NICs, switches, etc. The Monitor ports are typically connected to a LAN analyzer. Traffic between the two devices can then be monitored by a LAN analyzer.

The MIL-250FXC is designed to operate in a 100Mbps configuration only. The device is fully capable of operating in a full-duplex mode.

Features

- Compact aluminum enclosure
- External power supply (5V DC, 1.5 Amp)
- Diagnostic LEDs

Installation

To install the MIL-250FXC:

1. Connect Port 1, Port 2, Monitor Port 1, and Monitor Port 2 to the appropriate devices.
2. Supply power to the MIL-250FXC using the power supply adapter included with the unit. Make sure the PWR LED illuminates.
3. Check the P1SD, MP1SD, P2SD, and MP2SD LEDs for proper status. This depends on the status of the devices connected to all four ports.

Please contact Digi's technical support if you experience difficulties installing the MIL-250FXC.

Theory of Operation

The MIL-250FXC is designed to "tap" the incoming data from the DCE and/or DTE lines to the Monitor port for performance evaluation and error detection.



The lines tapped will not affect the signal integrity or loading factor. Incoming data from either the DCE and DTE lines are regenerated before transmission.

The tapped data is fed to two transceivers for the LAN analyzer's connection. Signal integrity is guaranteed for the lines, and the connection to the LAN analyzer.

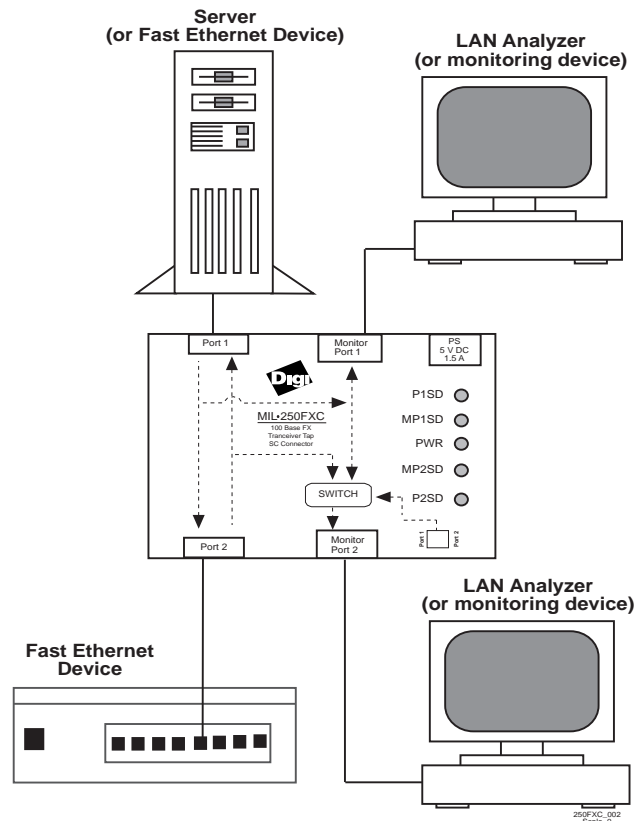

Figure 1. MIL-250FXC Passive Connections

Indicators

There are 5 LED indicators on the MIL-250FXC:

- **P1SD:** Port 1 Signal Detect. This LED illuminates when the MIL-250FXC receives a signal on port 1. It is yellow.
- **MP1SD:** Monitor Port One Signal Detect. This LED illuminates when the device receives a signal on Monitor Port One. It is yellow.
- **PWR:** Power. This LED illuminates when the device is powered up (using the power supply adapter). It is green.
- **MP2SD:** Monitor Port Two Signal Detect. This LED illuminates when the device receives a signal on Monitor Port Two. It is yellow.

- **P2SD:** Port 2 Signal Detect. This LED illuminates when the MIL-250FXC receives a signal on port 2. It is yellow.

Switch Setting

SW1: If it is in the Up position, then data coming into Port 1 will be transferred to Monitor Port 2.

SW1: If it is in the Down position, then data coming into Port 2 will be transferred to Monitor Port 2.

Note: Data from Port 1 is always transferred to Monitor Port 1.

SW2: Reserved.

Specifications

SC Fiber Connector

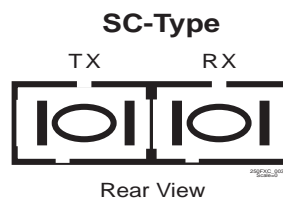

Figure 2.SC-type Connector

SC connector: Average Output Power

- Wavelength: 1261-1360 nm
- Cable specs.: 62.5/125 μm
- Min. optical power output: -19.0 dBm
- Max. optical power output: -14.0 dBm
- Receive sensitivity: -30.0 dBm
- Max. optical power input: -14 dBm
- Supports up to 2 km of multi-mode cable

Data Rate: 100Mbps, NRZI encoded.

Climate: Storage Temperature

- Minimum: -25° C
- Maximum: 75° C



Operating Conditions

Table 1: Recommended Operation Conditions

Parameters	Minimum	Maximum
Operating Temperature	+5° C	40° C
Humidity: Non-condensing	10%	95%
Signal Output Load	35 ohm	75 ohm
Supply Voltage	4.75 V	5.25 V

Power Supply

External power is required for the MIL-250FXC. The system board draws 1.25 A at normal operation in room temperature of 25° C.

- A 110 V AC wall mount power supply unit for domestic use (supplied).
- A 220 V AC with IEC receptacle converting to 5 V DC 1.5 Amp for international use (supplied for international use only).

Delay: ≤ 10 nanoseconds.

Dimensions: 4.0" x 3.5" x 1"

Legal

Regulatory Approvals

- FCC Class A
- UL 1950
- CSA 22 No. 950
- EN60950
- CE
 - EN55022 Class B
 - EN50082-1

Canadian EMI Notice

This Class A digital apparatus meets all the requirements of the Canadian Interference-Causing Equipment Regulations.

Cet appareil numérique de la classe A respecte toutes les exigences du Règlement sur le matériel brouilleur du Canada.

European Notice

Products with the CE Marking comply with both the EMC Directive (89/336/EEC) and the Low Voltage Directive (73/23/EEC) issued by the commission of the European Community. Compliance with these directives implies conformity to the following European Norms:

- EN55022 (CISPR 22) - Radio Frequency Interference
- EN50082-1 (IEC801-2, IEC801-3, IEC801-4) - Electromagnetic Immunity
- EN60950 (IEC950) - Product Safety

Five-Year Limited Warranty

Digi International warrants to the original consumer or purchaser that each of its products, and all components thereof, will be free from defects in material and/or workmanship for a period of five years from the original factory shipment date. Any warranty hereunder is extended to the original consumer or purchaser and is not assignable.

Digi makes no express or implied warranties including, but not limited to, any implied warranty of merchantability or fitness for a particular purpose, except as expressly set forth in this warranty. In no event shall Digi be liable for incidental or consequential damages, costs, or expenses arising out of or in connection with the performance of the product delivered hereunder. Digi will in no case cover damages arising out of the product being used in a negligent fashion or manner.

To Contact Digi

For prompt response when calling for service information, have the following information ready:

- Product serial number and rev.
- Date of purchase
- Vendor or place of purchase

Reach Digi Technical Support at 408/744-2751
Or E-mail at "sun-tech@dgii.com"

Address: 1299 Orleans Drive
Sunnyvale, CA 94089
Voice: 408/744-2775
Fax: 408/744-2793
E-mail: info@dgii.com